

DASH NUMBER	CABLES ACCOMMODATED	ASSEMBLE PER
-23	275-3930, MICRODOT	TAI-127
-24	202-3934, MICRODOT	TAI-125
-24A	9530A5117, RAYCHEM	TAI-127
-27	202-3927, MICRODOT ⁵ 73-1317911-1, SYLVANIA	TAI-125
-29	TWC-124-1A TWC-78-1	
-30	8441, BELDEN ⁴ 761A, W.E.CO.	
-32	TRC-50-1	TAI-127
-33	TRC-75-1	
-43	250-4044/250-4045 293-3930 MICRODOT	TAI-174
-45	10602, RAYCHEM	TAI-125
-47	MI7/176-00002 ⁵	
-49	TWAC-78-1F2 ⁵	
-55	TWCP-124-3 ⁴	TAI-174
-56	GC875GC1, GRUMMAN	
-57	GC875GB1, GRUMMAN	
-58	GC875TM24H, GRUMMAN	TAI-125

DATA CONTAINED IN THIS DOCUMENT IS PROPRIETARY TO TROMPETER ELECTRONICS INC. AND SHALL NOT BE DISCLOSED, COPIED OR USED FOR PROCUREMENT OR MANUFACTURE WITHOUT EXPRESS WRITTEN PERMISSION.

REVISIONS

REV	DESCRIPTIONS	DATE	APPROVED
P	REVISED PER ECO #16414	8/15/07	AWM

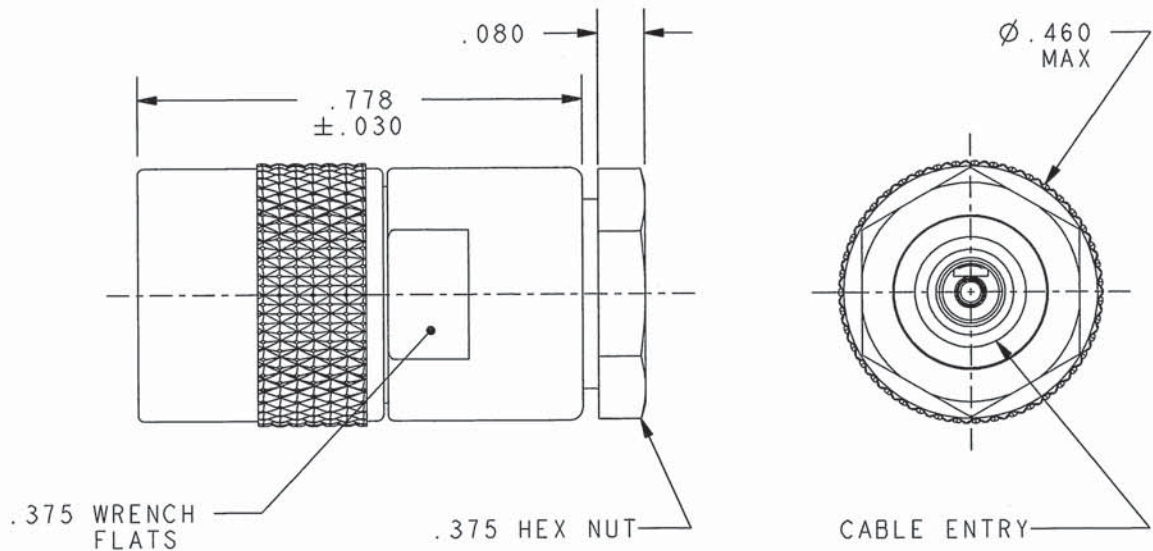
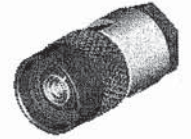

-29 SHOWN

⁵ .187 LARGE JACKET SLITS MAY BE REQUIRED FOR EASE OF ASSEMBLY

⁴ NOT WRENCH CRIMP

3. CONCENTRIC TWINAX/TRIAX SUBMINIATURE THREADED TTM CABLE PLUG

2. IF SAFETY WIRE TYPE REQUIRED ADD SUFFIX "S" TO MODEL NUMBER (PL3155S)

1. FINISH: NICKEL

INTERPRET DRAWING PER MIL-STD-100. DIMENSIONS ARE IN INCHES AND INCLUDE FINISH THICKNESS UNLESS OTHERWISE SPECIFIED.		TOL: UNLESS SPECIFIED. .XX ± .02 .XXX ± .010 ANGLE ± 1°			
DRN	JLM 7-19-07	MATERIAL:	TITLE:		
CHK	COG 8/13/07	FINISH:	PL3155/PL3155S		
MANUF		SIZE	CAGE CODE	DRAWING NO.	REV.
APPROV	AWM 8/14/07	A	14949	310-0047	P
PROJ FILE NO.		SCALE	DATE	SHEET	