

RED IS ORIGINAL

DISK # DWG B12Z DATA CONTAINED IN THIS DOCUMENT IS PROPRIETARY TO TROMPETER ELECTRONICS INC. AND SHALL NOT BE DISCLOSED, COPIED OR USED FOR PROCUREMENT OR MANUFACTURE WITHOUT EXPRESS WRITTEN PERMISSION.

REV		DESCRIPTION	3-0123	SH 1
REV	EO	DESCRIPTION	DWN	APPROVED
E	10049	PICTORIALLY CHANGED 1.00 FLAIED SEALING SLEEVE TO STRAIGHT (1.25) LONG SEALING SLEEVE; GENERAL UPDATE	DKC	<i>DKC</i> 12/15/92

TABLE 1

DASH NO	MODEL NO	CENTER CONTACT/INTMD CONTACT TYPE
-1	BJ3459AC P	SOCKET/PIN
-2	BJ3459AC S	PIN/SOCKET

TABLE 2

CABLE GROUP NO	CABLES ACCOMMODATED	ASSEMBLE PER
-201	M17/176-00002	TAI-162
-202	TWC-78-1, TROMPETER	
-203	TWC-124-1A, TROMPETER	
-204	10802, RAYCHEM	
-205	TWAC-78-1F2, TROMPETER	
-206	782600130, RAYCHEM	
-208	202-3927, MICRODOT	
-209	202-3942, MICRODOT	
-212	2524E0114, RAYCHEM	
-217	9CB7STM24H GRUMMAN	
-218	EPD221888, RAYCHEM	
-219	252601114, RAYCHEM	
-220	9CB75RR1 GRUMMAN	
-221	10614, RAYCHEM	
-222	10613, RAYCHEM	
-223	HMS2-1149, HUGHES	

INCH	MM
.003	0.08
.0050	0.13
.010	0.25
.030	0.76
.047	1.19
.125	3.18
.255	6.48
.274	6.98
.278	7.05
.330	8.38
.334	8.48
.335	8.51
.43	10.92
.4375	11.11
.620	15.75
1.00	25.40
1.365	34.67

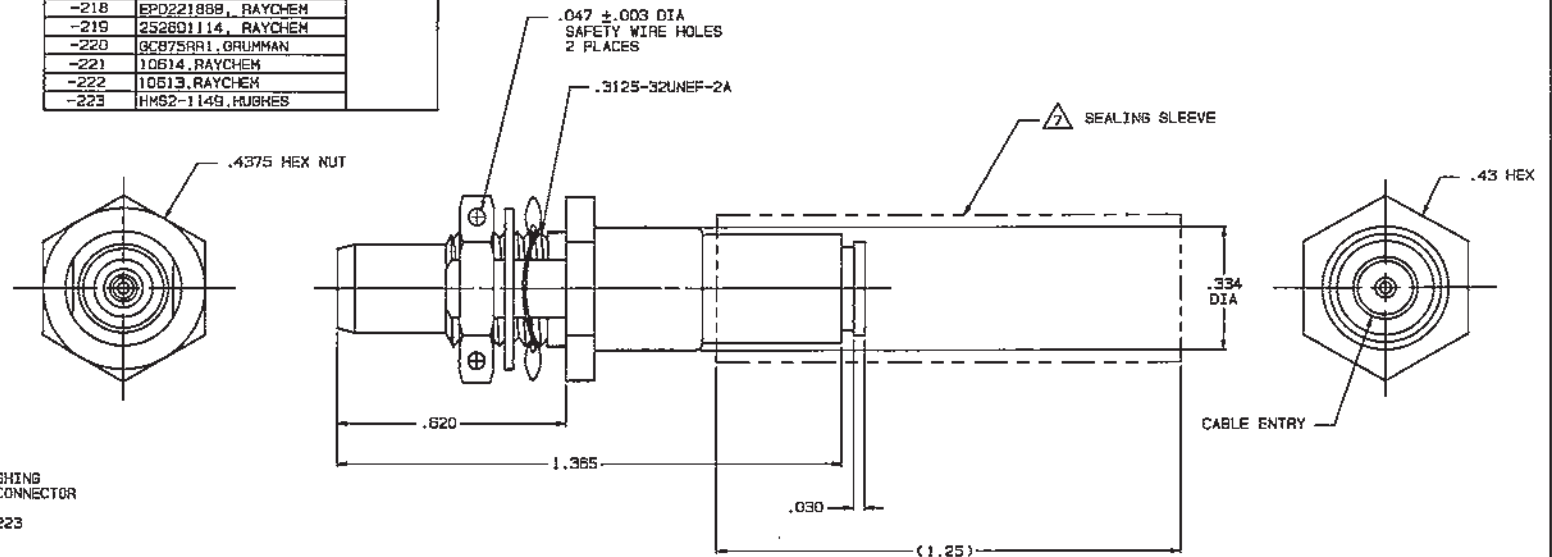

7. SEALING SLEEVE & CRIMP BUSHING SUPPLIED LOOSE WITH EACH CONNECTOR EXCEPT NOT USED ON -205, -208 & -223

6. EXAMPLE OF COMPLETE MODEL NO:

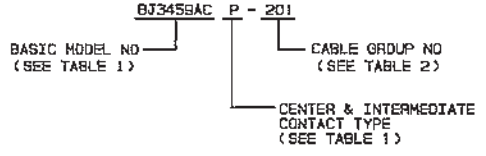

5. EXAMPLE OF COMPLETE PART NO:

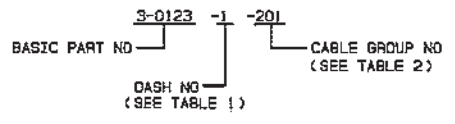

4. MAX PANEL THK .125

3. CONCENTRIC TWIMAX 4 PIECE ASSY, FULL CRIMP NONINSULATED BULKHEAD MOUNT RECEPTACLE, SOCKET CENTER CONTACT AND PIN INTERMEDIATE CONTACT OR PIN CENTER CONTACT AND SOCKET INTERMEDIATE CONTACT

2. FINISH: TFS-1U (500 HOURS SALT SPRAY; NICKEL)

1. ALL DIM ARE IN INCHES

-1-221 SHOWN

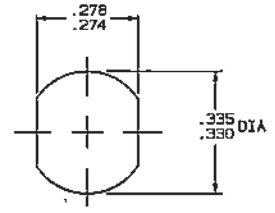

RECOMMENDED PANEL CUTOUT

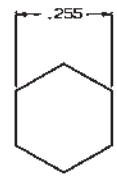

RECOMMENDED HEX CRIMP

QTY	DESCRIPTION	PART NUMBER	ITEM
TO, UNLESS SPECIFIED			
XX ± .03			
XXX ± .010			
XXXX ± .0050			
ANGLES			
DWN	DKC 12-7-92	MATERIAL	OOE IDENT
CHK	<i>DKC 12-9-92</i>	14948	DRAWING NO.
ENGR	-		3-0123
REV			E
NEXT ASSY	APPR <i>DKC 12-15-92</i>	SCALE 4/1	DATE 10-7-87
			SHEET 1 OF 2