

SECTION A-A

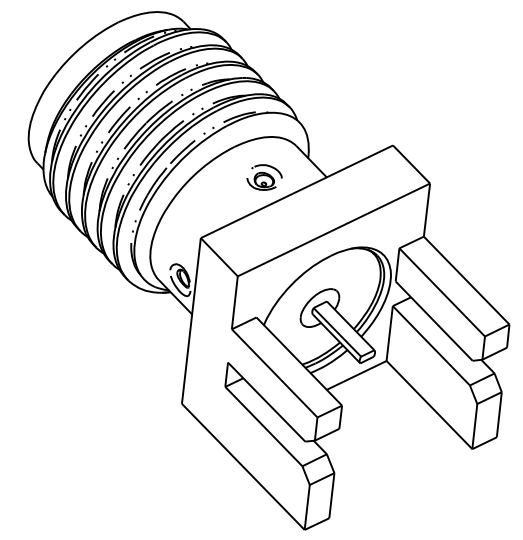

NOTES: UNLESS OTHERWISE SPECIFIED.

1. MATERIAL & FINISH:

- 1.1 BODY: (142-0721-821) GOLD PLATED BRASS
(142-0721-826) NICKEL PLATED BRASS
- 1.2 INSULATORS: PTFE (TEFLON)
- 1.3 CENTER CONTACT: GOLD PLATED BERYLLIUM COPPER

2. ELECTRICAL SPECIFICATIONS:

- 2.1 IMPEDANCE: 50 OHMS
- 2.2 FREQUENCY RANGE: 0-18 GHz
- 2.3 WORKING VOLTAGE: 335 VRMS MAX AT SEA LEVEL
- 2.4 DIELECTRIC WITHSTANDING VOLTAGE: 1000 VRMS MIN AT SEA LEVEL
- 2.5 INSULATION RESISTANCE: 5000 MEGOHM MIN
- 2.6 CONTACT RESISTANCE:
 - CENTER CONTACT - INITIAL 3.0 MILLIOHM MAX,
AFTER ENVIRONMENTAL 4.0 MILLIOHM MAX
 - OUTER CONDUCTOR - INITIAL 2.0 MILLIOHM MAX,
AFTER ENVIRONMENTAL NOT APPLICABLE
- 2.7 CORONA LEVEL: 250 VOLTS MIN AT 70,000 FEET
- 2.8 RF HIGH POTENTIAL WITHSTANDING VOLTAGE: 670 VRMS MIN AT 4 AND 7 MHZ

3. MECHANICAL SPECIFICATIONS:

- 3.1 ENGAGE/DISENGAGE TORQUE: 2 INCH POUNDS MAX
- 3.2 MATING TORQUE: 7-10 INCH POUNDS
- 3.3 CONTACT RETENTION: 6 LBS MIN AXIAL FORCE
4 IN-OZ MIN RADIAL TORQUE
- 3.4 DURABILITY: 500 CYCLES MIN

4. ENVIRONMENTAL:

- 4.1 (MEETS OR EXCEEDS THE APPLICABLE PARAGRAPH OF MIL-PRF-39012)
- 4.2 THERMAL SHOCK: MIL-STD-202, METHOD 107, CONDITION B
- 4.3 OPERATING TEMPERATURE: -65° C TO 165° C
- 4.4 CORROSION: MIL-STD-202, METHOD 101, CONDITION B
- 4.5 SHOCK: MIL-STD-202, METHOD 213, CONDITION I
- 4.6 VIBRATION: MIL-STD-202, METHOD 204 CONDITION D
- 4.7 MOISTURE RESISTANCE: MIL-STD-202, METHOD 106

<p>This PROPRIETARY Document is property of Cinch Connectivity Solutions. It is confidential in nature, non-transferable, and issued with the clear understanding that it is not to be traced or copied without permission and is returnable upon demand.</p> <p>INTERPRET DRAWING IN ACCORDANCE WITH ASME Y14.5-2009.</p>		JOHNSON	
	RoHS2 2011/65/EU	Title: JACK ASSEMBLY END LUNCH SMA	
	.XX ±.02 .XXX ±.005 ANGLES ±2°	Model No. 142-0721-861/870	
	Size B DO NOT SCALE DRAWING	Date 3/2/2016	Sheet 1 OF 1