

PART NUMBER	ITEM ① BCDY	ITEM ② CONTACT	ITEM ③ INSULATOR	ITEM ④ SEAL RING	ITEM ⑤ WASHER	ITEM ⑥ NUT
142-0594-401	BRASS GOLD PL .00001 MIN OVER NICKEL PL .00005 MIN OVER COPPER PL .00005 MIN	BERYLLIUM COPPER GOLD PL .00003 MIN OVER NICKEL PL .00005 MIN OVER COPPER PL .00005 MIN	TEFLON	SILICONE RUBBER	BRASS GOLD PL .00001 MIN OVER NICKEL PL .00005 MIN OVER COPPER PL .00005 MIN	BRASS GOLD PL .00001 MIN OVER NICKEL PL .00005 MN OVER COPPER PL .00005 MIN
142-0594-408	BRASS NICKEL PL .0001 MIN OVER COPPER PL .00005 MIN	BERYLLIUM COPPER GOLD PL .00003 MIN OVER NICKEL PL .00005 MIN OVER COPPER PL .00005 MIN	TEFLON	SILICONE RUBBER	BRASS NICKEL PL .0001 MIN OVER COPPER PL .00005 MIN	BRASS NICKEL PL .0001 MIN OVER COPPER PL .00005 MIN

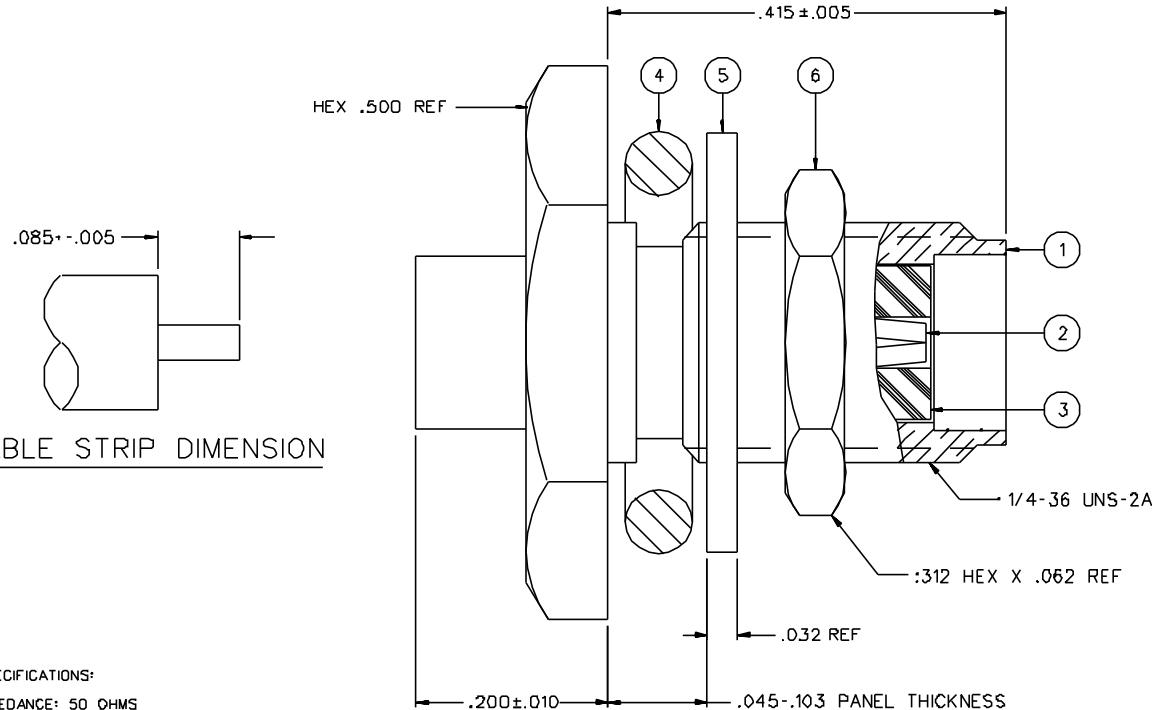

CABLE STRIP DIMENSION

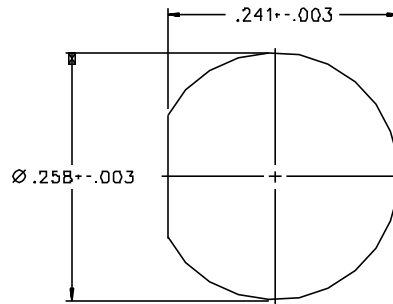

MOUNTING HOLE

NOTES:

1. SPECIFICATIONS:

IMPEDANCE: 50 OHMS  
 FREQUENCY RANGE: 0-18 GHz  
 VSWR: 1.05+-.008 F MAX (F IN GHz)  
 WORKING VOLTAGE: 500 VRMS MAX AT SEA LEVEL  
 DIELECTRIC WITHSTANDING VOLTAGE: 1500 VRMS MIN AT SEA LEVEL  
 INSULATION RESISTANCE: 5000 MEGOHM MIN  
 CONTACT RESISTANCE:  
 CENTER CONTACT - INITIAL 3.0 MILLIOHM MAX, AFTER ENVIRONMENTAL 4.0 MILLIOHM MAX  
 OUTER CONDUCTOR - INITIAL 2.0 MILLIOHM MAX AFTER ENVIRONMENTAL NOT APPLICABLE  
 BODY TO CABLE - 0.5 MILLIOHM MAX  
 CORONA LEVEL: 375 VOLTS MIN AT 70,000 FEET  
 INSERTION LOSS: <math>\sqrt{0.3}</math> (F IN GHz) AT 10 GHz  
 RF LEAKAGE: -90 DB MIN AT 2 TO 3 GHz  
 RF HIGH POTENTIAL WITHSTANDING VOLTAGE: 1000 VRMS MIN AT 5 TO 7.5 MHz

MECHANICAL:

ENGAGE/DISENGAGE TORQUE: 2 INCH-POUNDS MAX  
 MATING TORQUE: 7-10 INCH POUNDS  
 COUPLING PROOF TORQUE: NOT APPLICABLE  
 COUPLING NUT RETENTION: NOT APPLICABLE  
 CONTACT RETENTION: NOT APPLICABLE  
 CABLE ACCEPTABILITY: RG 402 DIA .141 SEMIRIGID  
 CABLE HEX CRIMP SIZE: NOT APPLICABLE  
 CABLE RETENTION: 6D LBS MIN AXIAL FORCE  
 55 INCH-OUNCE MIN TORQUE  
 DURABILITY: 500 CYCLES MIN

ENVIRONMENTAL:

(MEETS OR EXCEEDS THE APPLICABLE PARAGRAPH OF MIL-PRF-39012)  
 THERMAL SHOCK: MIL-STD-202, METHOD 107, CONDITION C, EXCEPT 115 DEG C HIGH TEMP  
 OPERATING TEMPERATURE: -65 DEG C TO 165 DEG C  
 CORROSION: MIL-STD-202, METHOD 101, CONDITION B  
 SHOCK: MIL-STD-202, METHOD 213, CONDITION I  
 VIBRATION: ML-STD-202, METHOD 204, CONDITION D  
 MOISTURE RESISTANCE: MIL-STD-202, METHOD 106

DRAWING NO. C - 142-0594-401/410			
0 REVISIONS			
ENGINEERING RELEASE			
01	01-29-90	E J A	02-05-90 ECO 24294
ADDED: 115° HIGH TEMP TO THERMAL SHOCK SPEC.			
02	02-27-90	E J A	3-8-90 ECO 24405
SILICONE RUBBER WAS BUNA-N. HEX .500 REF WAS HEX .500-.010. .415+-.005 WAS .415-.D10 DIA .241+-.003 WAS DIA .241+.000-.005, DIA .258+-.003 WAS DIA .258+.000-.005. 10 GHz WAS 9-12.4 GHz. DELETED: 615-.010 .539-.010. ADDED: 200-.D10 .D45-.D3 PANEL THICKNESS .032 REF .312 HEX X .062 THK REF. 1/4-36 UNS-2A			
3	2-22-91	R H A	2-28-91 ECO 24972
VERSION UPDATE.			
4	9-6-91	D B A	ECO 40497
UPDATED COMPANY LOGOS			
* REVISION NUMBER FOLLOWED BY AN ALPHA * * CHARACTER INDICATES DRAWING CHANGE * * CATION ON PART NUMBER ADDITION ONLY *			
4a	5-2-02	R H A	5-23-02 ECN 48388

CUSTOMER DRAWING

THIS DRAWING TO BE INTERPRETED PER ANSI Y 14.5M - 1982

"µSTATION"

COMPANY CONFIDENTIAL

TOLERANCE UNLESS OTHERWISE SPECIFIED	DRAWN BY E J	DATE 9-13-89	JOHNSON Cinch Connectivity Solutions 299 Johnson Ave. Ste. 100 Worces, MA 06095 1-800-247-8256	
DECIMALS .XX	CHECKED BY	DATE	TITLE JACK ASSEMBLY STRAIGHT CABLED BULKHEAD SMA, RG 402	
.XXX	APPROVED BY GLO	DATE 1-30-9D	CODE NO.	DRAWING NO. C - 142-0594-401/410
MATL	APPROVED BY RJB	DATE 1-30-9D	SCALE 10:1	U/W INCH SHEET 2 OF 2
FINISH	RELEASE DATE	DATE 2-5-90		