

PART NUMBER
147-0701-281

REV	ECO	DATE
1	INITIAL RELEASE	09SEP2021

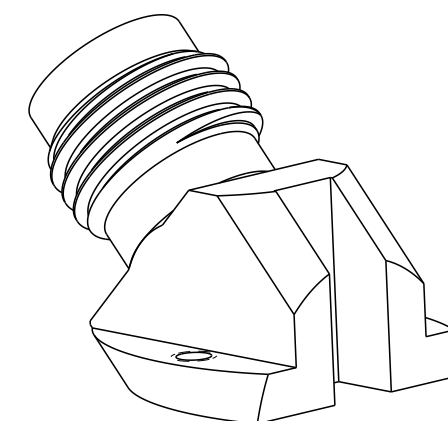
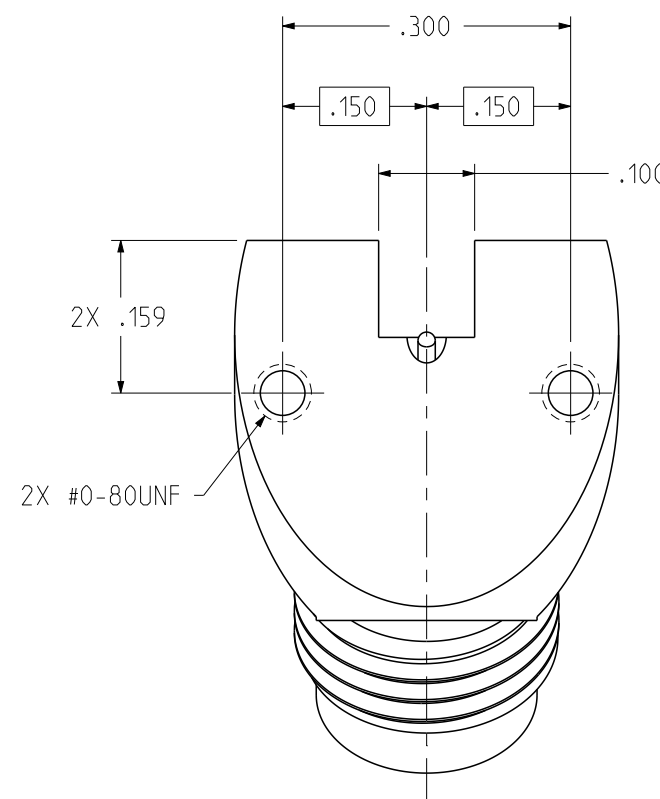
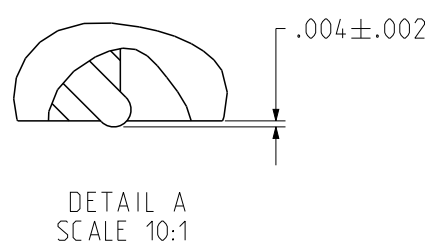
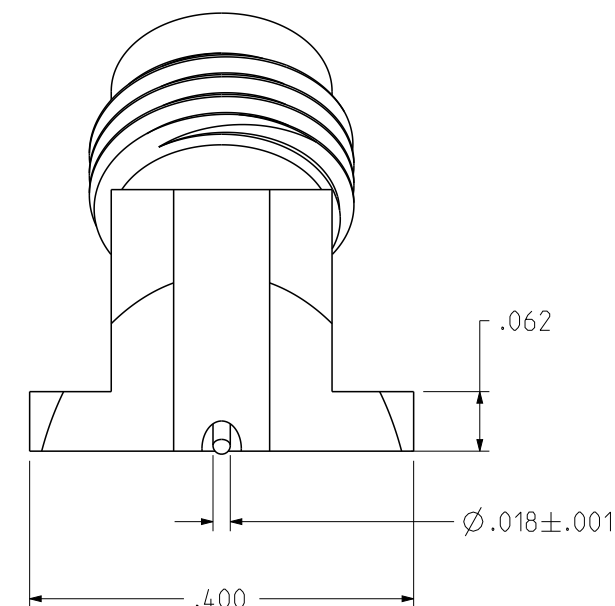
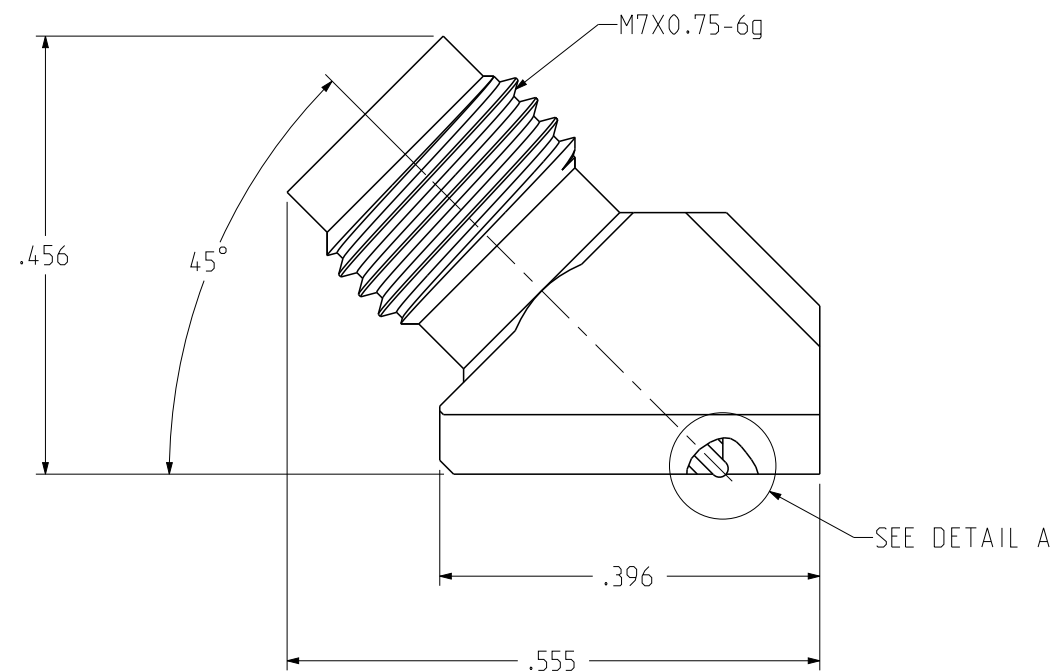

SCALE 4:1

NOTES:

1. MATERIALS AND FINISH:
 - 1.1 BODIES: GOLD PLATED BRASS
 - 1.2 CONTACT: GOLD PLATED BERYLLIUM COPPER
 - 1.3 INSULATOR: PTFE / ULTEM 1000
2. ELECTRICAL SPECIFICATIONS:
 - 2.1 IMPEDANCE: 50 OHMS
 - 2.2 FREQUENCY RANGE: DC-50 GHz
 - 2.3 VSWR: DEPENDENT ON APPLICATION
 - 2.4 WORKING VOLTAGE: 150 VRMS MAX AT SEA LEVEL
 - 2.5 DIELECTRIC WITHSTANDING VOLTAGE: 500 VRMS MIN AT SEA LEVEL
 - 2.6 INSULATION RESISTANCE: 5000 MEGOHM MIN
 - 2.7 CONTACT RESISTANCE:
 - 2.7.1 CENTER CONTACT - INTIAL 4.0 MILLIOHM MAX, AFTER ENVIRONMENTAL NOT APPLICABLE
 - 2.7.2 OUTER CONDUCTOR - INITIAL 2.5 MILLIOHM MAX, AFTER ENVIRONMENTAL NOT APPLICABLE
3. MECHANICAL SPECIFICATIONS:
 - 3.1 ENGAGEMENT/DISENGAGEMENT FORCE: 2 INCH-POUNDS MAX
 - 3.2 MATING TORQUE: 7 TO 10 INCH-POUNDS
 - 3.3 DURABILITY: 500 CYCLES MIN
4. ENVIRONMENTAL:

(MEETS OR EXCEEDS THE APPLICABLE PARAGRAPH OF MIL-PRF-39012)

 - 4.1 THERMAL SHOCK: MIL-STD-202, METHOD 107, CONDITION B
 - 4.2 OPERATING TEMPERATURE: -65 °C TO 165 °C
 - 4.3 CORROSION: MIL-STD-202, METHOD 101, CONDITION B
 - 4.4 SHOCK: MIL-STD-202, METHOD 213, CONDITION I
 - 4.5 VIBRATION: MIL-STD-202, METHOD 204, CONDITION D
 - 4.6 MOISTURE RESISTANCE: MIL-STD-202, METHOD 106

<p>This PROPRIETARY Document is property of Cinch Connectivity Solutions. It is confidential in nature, non-transferable, and issued with the clear understanding that it is not traced or copied without permission and is returnable upon demand.</p> <p>INTERPRET DRAWING IN ACCORDANCE WITH ASME Y14.5-2009.</p>	Model No: 147-0701-281/290	Title: JOHNSON 2.4MM JACK, 45 DEGREE, PCB MOUNT	
	RoHS <input checked="" type="checkbox"/> COMPLIANT (EU)/2015/863	Cage Code 3RD ANGLE PROJECTION	Drawing No. 147-0701-281/290
UNLESS OTHERWISE SPECIFIED UNITS: INCH .XX ± .01 .XXX ± .003 .XXXX ± .0010 ANGLE ± 2°	Drawn by: Roman Yao	Date: 09/09/2021	Size B DO NOT SCALE DRAWING
Workmanship Std/Sheet NONE		1 OF 1	