

PART NUMBER	ITEM ① BODY	ITEM ② SLIDER	ITEM ③ CONTACT	ITEM ④ INSULATOR	ITEM ⑤ RETENTION SPRING	ITEM ⑥ COUPLING NUT
145-0901-841	BRASS GOLD PL .00003 MIN OVER NICKEL PL .00005 MIN OVER COPPER	BRASS NICKEL PL .0001 MIN OVER COPPER PL .00005 MIN	BERYLLIUM COPPER GOLD PL .00005 MIN OVER NICKEL PL .00005 MIN OVER COPPER PL .00005 MIN	NOT SHOWN PLOYSTYRENE	NOT SHOWN BERYLLIUM COPPER UNPLATED	BERYLLIUM COPPER NICKLE PL .0001 MIN OVER COPPER PL .00005 MIN

REV	ECO	DATE
1	INITIAL RELEASE	29 JUN 2020
2	EC-2012009	08 DEC 2020

INSTRUCTIONS FOR USE:

1. WITH SLIDER IN THE ENGAGED POSITION THE CONNECTOR FUNCTIONS LIKE A STANDARD SMA CONNECTOR. TIGHTEN (SPIN) THE KNURLED NUT BY HAND TO OBTAIN FULL MATING ENGAGEMENT OR DISENGAGEMENT.

2. QUICK CONNECT FUNCTION:

2.1 WITH SLIDER IN THE DISENGAGED POSITION. SLIDE THE CABLED CONNECTOR ONTO THE JACK RECEPTACLE, OVER THE JACK THREADS BY PUSHING ON THE BACK OF KNURLED NUT.

2.2 ENGAGE THE SLIDER WHILE MAINTAINING LIGHT FORWARD PRESSURE ON THE NUT. THIS ACTION IS DONE BY SLIPPING YOUR FINGERS FROM THE NUT TO THE SLIDER IN ONE MOTION.

2.3 ONCE THE SLIDER IS ENGAGED THE KNURLED NUT CAN BE TURNED 1 TURN OR LESS TO OBTAIN FULL MATING ENGAGEMENT PERFORMANCE.

2.4 DISENGAGE THE CONNECTOR BY FIRST LOOSENING THE COUPLING NUT A PARTIAL TURN. THEN DISENGAGE THE SLIDER AND REMOVE THE CONNECTOR.

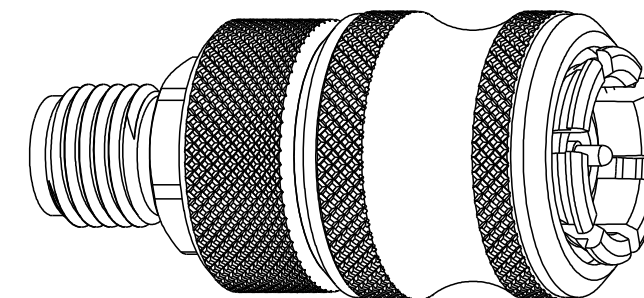

← SLIDER DISENGAGED (AS SHOWN)

SLIDER ENGAGED →

NOTES:

1. ELECTRICAL SPECIFICATIONS:

- 1.1 IMPEDANCE: 50 OHMS NOMINAL
- 1.2 FREQUENCY RANGE: DC-40 GHz
- 1.3 VSWR: 1.1 MAX. DC-32 GHz  
1.3 MAX. UP TO 40 GHz
- 1.4 WORKING VOLTAGE: 250 VRMS MAX AT SEA LEVEL
- 1.5 DIELECTRIC WITHSTANDING VOLTAGE: 1500 VRMS MIN AT SEA LEVEL
- 1.6 INSULATION RESISTANCE: 5000 MEGOHM MIN
- 1.7 CONTACT RESISTANCE:
  - 1.7.1 CENTER CONTACT - INITIAL 4.0 MILLIOHM MAX, AFTER ENVIRONMENTAL 6.0 MILLIOHM MAX
  - 1.7.2 OUTER CONDUCTOR - INITIAL 2.0 MILLIOHM MAX, AFTER ENVIRONMENTAL NOT APPLICABLE
  - 1.7.3 BRAID TO BODY - NOT APPLICABLE
- 1.8 CORONA LEVEL: 375 VOLTS MIN AT 70,000 FEET
- 1.9 INSERTION LOSS: 0.05/F MAX (F IN GHz)
- 1.10 RF LEAKAGE: -90 dB MIN AT 2.5 GHz
- 1.11 RF HIGH POTENTIAL WITHSTANDING VOLTAGE: 1000 VRMS MIN AT 4 MHz AND 7 MHz

2. MECHANICAL SPECIFICATIONS:

- 2.1 ENGAGE/DISENGAGE TORQUE: 2 INCH-POUNDS MAX
- 2.2 MATING TORQUE: 7-10 INCH-POUNDS
- 2.3 COUPLING PROOF TORQUE: 15 INCH-POUNDS MIN
- 2.4 COUPLING NUT RETENTION: 60 LBS MIN
- 2.5 CONTACT RETENTION: 6 LBS MIN AXIAL FORCE
- 2.6 CABLE ACCEPTABILITY: NOT APPLICABLE
- 2.7 CABLE HEX CRIMP SIZE : NOT APPLICABLE
- 2.8 CABLE RETENTION: NOT APPLICABLE
- 2.9 DURABILITY: 1000 CYCLES MIN

3. ENVIRONMENTAL:

- (MEETS OR EXCEEDS THE APPLICABLE PARAGRAPH OF MIL-A-55339)
- 3.1 THERMAL SHOCK: MIL-STD-202, METHOD 107, CONDITION B
- 3.2 OPERATING TEMPERATURE: -65 °C TO 165 °C
- 3.3 CORROSION: MIL-STD-202, METHOD 101, CONDITION B
- 3.4 SHOCK: MIL-STD-202, METHOD 213, CONDITION I
- 3.5 VIBRATION: MIL-STD-202, METHOD 204, CONDITION D
- 3.6 MOISTURE RESISTANCE: MIL-STD-202, METHOD 106

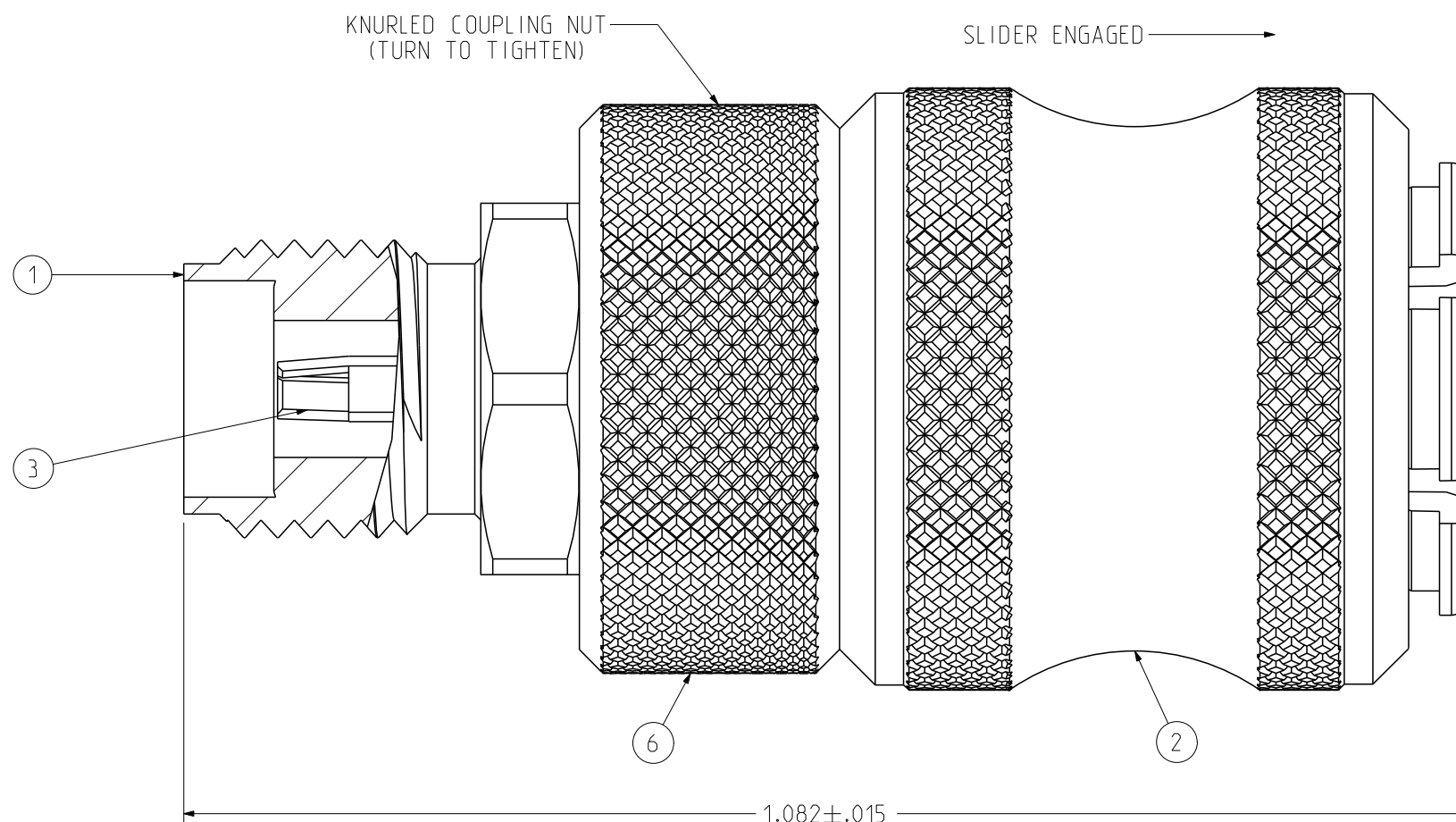

<p>This PROPRIETARY document is property of Cinch Connectivity Solutions. It is confidential in nature, non-transferable, and issued with the clear understanding that it is not to be traced or copied without permission and is returnable soon thereafter.</p> <p>INTERPRET DRAWINGS IN ACCORDANCE WITH ASME Y14.5-2009.</p>	Model No. 145-0901-841/850	JOHNSON		
	RoHS <input checked="" type="checkbox"/> (EU) 2015/863 COMPLIANT	Cage Code	Title: 2.92MM QUICK CONNECT ADAPTOR IN SERIES, PLUG TO JACK	
	UNLESS OTHERWISE SPECIFIED UNITS: INCH	3RD ANGLE PROJECTION	Drawn by: Jimmy Chen	Drawing No. 145-0901-841/850
	.XX ± .01 .XXX ± .003 .XXXX ± .0010 ANGLE ± 2°	Date: 06/29/2020	Size B	DO NOT SCALE DRAWING
		Workmanship Std/Sheet NONE	1 OF 1	