

PART NUMBER	ITEM ① BODY, SMA	ITEM ② BODY, SMPM	ITEM ③ CONTACT	ITEM ④ INSULATOR
134-1001-004	BRASS GOLD PL .00003 MIN OVER NICKEL PL .00005 MIN OVER COPPER	BERYLLIUM COPPER GOLD PL .00005 MIN OVER NICKEL PL .00005 MIN OVER COPPER PL .00005 MIN	BERYLLIUM COPPER GOLD PL .00005 MIN OVER NICKEL PL .00005 MIN OVER COPPER PL .00005 MIN	TEFLON

REV	ECO	DATE
1	INITIAL RELEASE	15APR2020
2	EC-2007007	07JUL2020
3	EC-2108016	25AUG2021

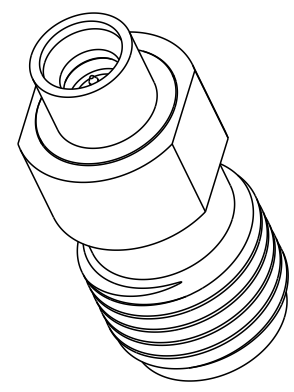
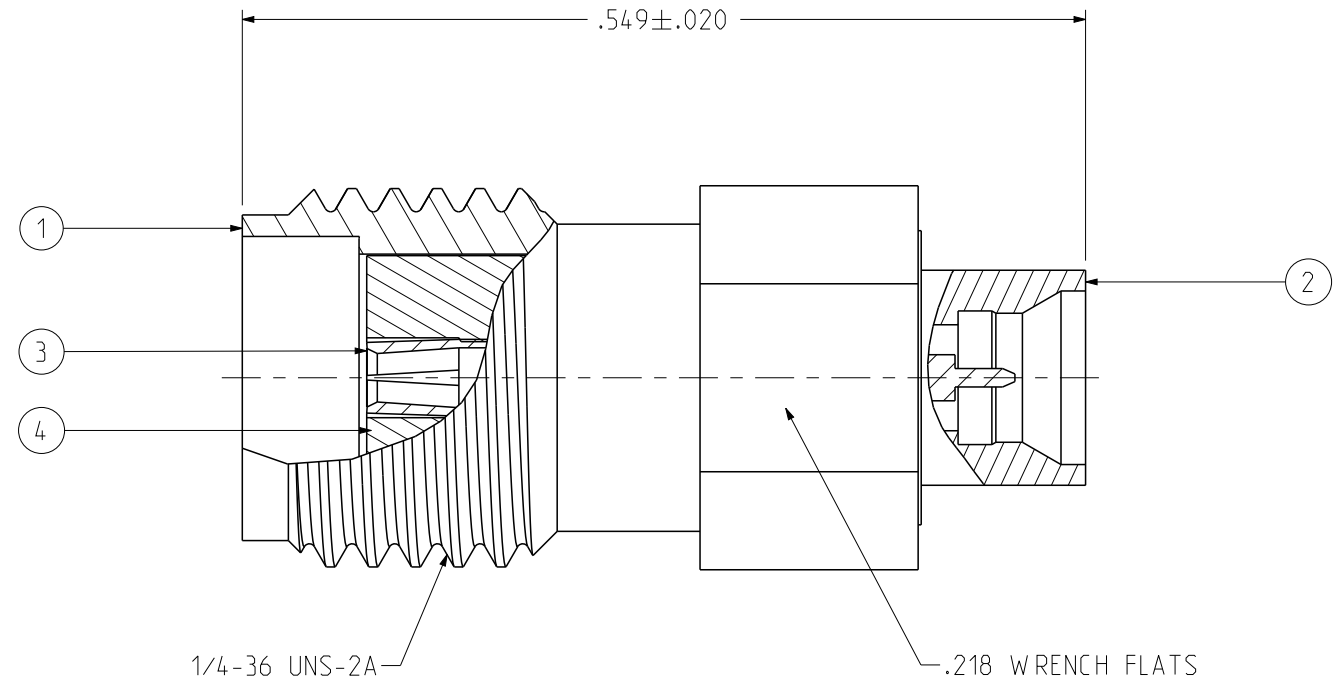

SCALE 4:1

NOTES:

1. ELECTRICAL SPECIFICATIONS:

- 1.1 IMPEDANCE: 50 OHMS
- 1.2 FREQUENCY RANGE: DC-26.5 GHz
- 1.3 VSWR: 1.25 MAX. DC-18 GHz
1.30 MAX. 18-26.5 GHz
- 1.4 INSERTION LOSS: 0.12√F dB MAX (F IN GHz)
- 1.5 WORKING VOLTAGE: 335 VRMS MAX AT SEA LEVEL
- 1.6 DIELECTRIC WITHSTANDING VOLTAGE: 325 VRMS MIN AT SEA LEVEL
- 1.7 INSULATION RESISTANCE: 5000 MEGOHM MIN
- 1.8 CONTACT RESISTANCE:
 - 1.8.1 CENTER CONTACT - INTIAL 6 MILLIOHM MAX, AFTER ENVIRONMENTAL NOT APPLICABLE
 - 1.8.2 OUTER CONDUCTOR - INITIAL 2 MILLIOHM MAX, AFTER ENVIRONMENTAL NOT APPLICABLE
- 1.9 RF LEAKAGE: NOT APPLICABLE

2. MECHANICAL SPECIFICATIONS:

- 2.1 ENGAGEMENT FORCE: SMPM FULL DETENT (FD) 4.5 LBS TYPICAL,
DISENGAGEMENT FORCE: FD 6.5 LBS TYPICAL
- 2.2 ENGAGE/DISENGAGE TORQUE (SMA): 2 IN LBS MAX
- 2.3 MATING TORQUE (SMA): 7-10 IN LBS MAX
- 2.4 DURABILITY: 500 CYCLES MIN (SMA), 100 CYCLES MIN (SMPM FD)

3. ENVIRONMENTAL:

- (MEETS OR EXCEEDS THE APPLICABLE PARAGRAPH OF MIL-PRF-39012)
- 3.1 THERMAL SHOCK: MIL-STD-202, METHOD 107, CONDITION B
 - 3.2 OPERATING TEMPERATURE: -65 °C TO 165 °C
 - 3.3 CORROSION: MIL-STD-202, METHOD 101, CONDITION B
 - 3.4 SHOCK: MIL-STD-202, METHOD 213, CONDITION B
 - 3.5 VIBRATION: MIL-STD-202, METHOD 204, CONDITION B
 - 3.6 MOISTURE: MIL-STD-202, METHOD 106

	Model No:	134-1001-004	JOHNSON	
	RoHS <input checked="" type="checkbox"/> (EU)/2015/863 COMPLIANT UNLESS OTHERWISE SPECIFIED UNITS: INCH .XX ± .01 .XXX ± .003 .XXXX ± .0010 ANGLE ± 2°	Cage Code 3RD ANGLE PROJECTION Drawn by: Roman.Yao Date: 4/15/2020	Title: ADAPTER, SMPM FULL DETENT MALE TO SMA JACK Drawing No. 134-1001-004	REV. 3
This PROPRIETARY Document is property of Cinch Connectivity Solutions. It is confidential in nature, non-transferable, and issued with the clear understanding that it is not traced or copied without permission and is returnable upon demand. INTERPRET DRAWING IN ACCORDANCE WITH ASME Y14.5-2009.	Size B DO NOT SCALE DRAWING	Workmanship Std/Sheet NONE	1 OF 1	