

PART NUMBER	ITEM ① BODY, SMA	ITEM ② BODY, SMPM	ITEM ③ CONTACT	ITEM ④ INSULATOR
134-1001-003	BRASS GOLD PL .00003 MIN OVER NICKEL PL .00005 MIN OVER COPPER	BERYLLIUM COPPER GOLD PL .00005 MIN OVER NICKEL PL .00005 MIN OVER COPPER PL .00005 MIN	BERYLLIUM COPPER GOLD PL .00005 MIN OVER NICKEL PL .00005 MIN OVER COPPER PL .00005 MIN	TEFLON

REV	ECO	DATE
1	INITIAL RELEASE	15APR2020
2	EC-2007007	07JUL2020
3	EC-2108016	25AUG2021

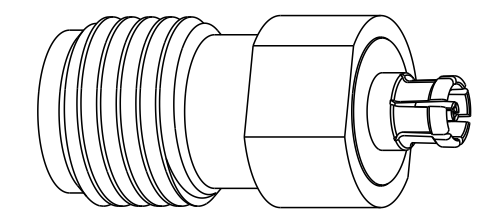
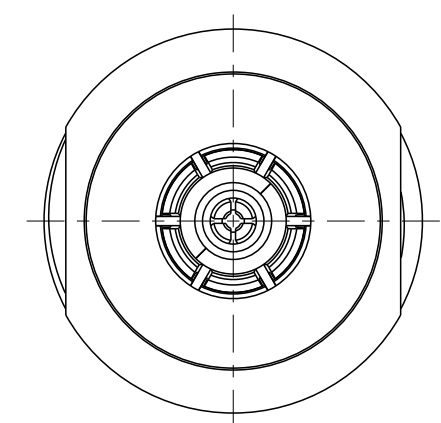
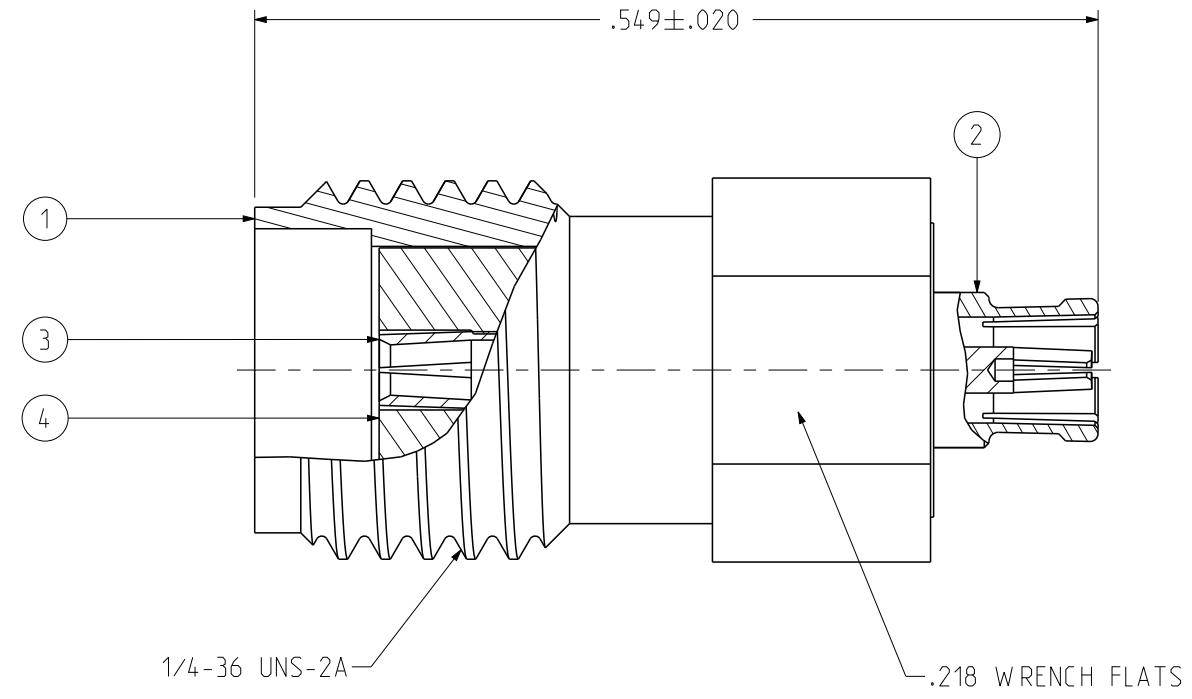

SCALE 4:1

NOTES:

1. ELECTRICAL SPECIFICATIONS:
  - 1.1 IMPEDANCE: 50 OHMS
  - 1.2 FREQUENCY RANGE: DC-26.5 GHz
  - 1.3 VSWR: 1.25 MAX. DC-18 GHz  
1.30 MAX. 18-26.5 GHz
  - 1.4 INSERTION LOSS: 0.12√F dB MAX (F IN GHz)
  - 1.5 WORKING VOLTAGE: 335 VRMS MAX AT SEA LEVEL
  - 1.6 DIELECTRIC WITHSTANDING VOLTAGE: 325 VRMS MIN AT SEA LEVEL
  - 1.7 INSULATION RESISTANCE: 5000 MEGOHM MIN
  - 1.8 CONTACT RESISTANCE:
    - 1.8.1 CENTER CONTACT - INTIAL 6 MILLIOHM MAX, AFTER ENVIRONMENTAL NOT APPLICABLE
    - 1.8.2 OUTER CONDUCTOR - INITIAL 2 MILLIOHM MAX, AFTER ENVIRONMENTAL NOT APPLICABLE
  - 1.9 RF LEAKAGE: NOT APPLICABLE
2. MECHANICAL SPECIFICATIONS:
  - 2.1 ENGAGEMENT FORCE: SMPM FULL DETENT (FD) 4.5 LBS TYPICAL, DISENGAGEMENT FORCE: FD 6.5 LBS TYPICAL
  - 2.2 ENGAGE/DISENGAGE TORQUE (SMA): 2 IN LBS MAX
  - 2.3 MATING TORQUE (SMA): 7-10 IN LBS MAX
  - 2.4 DURABILITY: 500 CYCLES MIN (SMA), 100 CYCLES MIN (SMPM FD)
3. ENVIRONMENTAL: (MEETS OR EXCEEDS THE APPLICABLE PARAGRAPH OF MIL-PRF-39012)
  - 3.1 THERMAL SHOCK: MIL-STD-202, METHOD 107, CONDITION B
  - 3.2 OPERATING TEMPERATURE: -65 °C TO 165 °C
  - 3.3 CORROSION: MIL-STD-202, METHOD 101, CONDITION B
  - 3.4 SHOCK: MIL-STD-202, METHOD 213, CONDITION B
  - 3.5 VIBRATION: MIL-STD-202, METHOD 204, CONDITION B
  - 3.6 MOISTURE: MIL-STD-202, METHOD 106

<p>This PROPRIETARY Document is property of Cinch Connectivity Solutions. It is confidential in nature, non-transferable, and issued with the clear understanding that it is not traced or copied without permission and is returnable upon demand.</p> <p>INTERPRET DRAWING IN ACCORDANCE WITH ASME Y14.5-2009.</p>	Model No: 134-1001-003	JOHNSON		
	RoHS <input checked="" type="checkbox"/> (EU)/2015/863 COMPLIANT	Cage Code	Title: ADAPTER, SMPM FEMALE TO SMA JACK	
	UNLESS OTHERWISE SPECIFIED UNITS: INCH	3RD ANGLE PROJECTION	Drawing No. 134-1001-003	REV. 3
	.XX ± .01 .XXX ± .003 .XXXX ± .0010 ANGLE ± 2°	Drawn by: Roman.Yao Date: 4/15/2020	Size B DO NOT SCALE DRAWING	Workmanship Std/Sheet NONE 1 OF 1