

DRAWING REVISIONS (RELEASE DATE ON FILE)			
REV	DOCUMENT	APP	APPROVAL DATE
01	SALES DRAWING	JW	12/15/23

SOCKET CONNECTOR

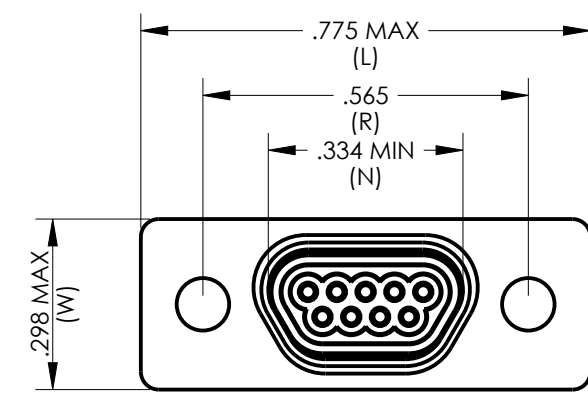

PLUG CONNECTOR

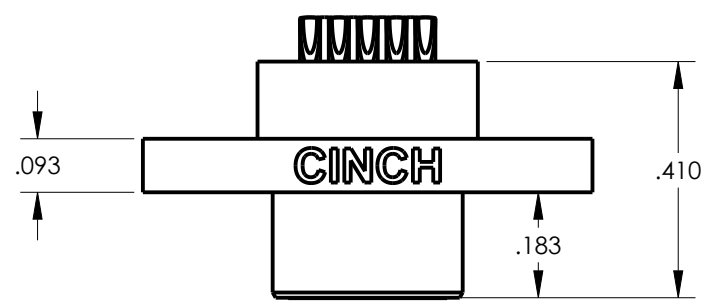
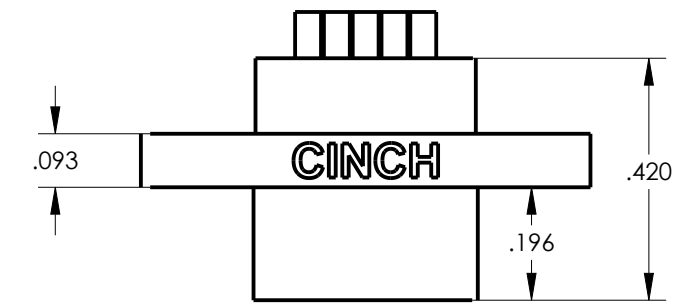
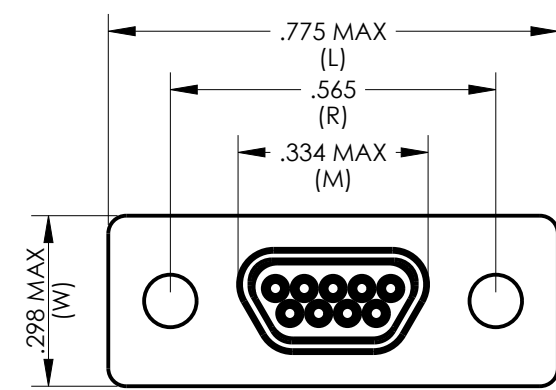

Notes:

1. DIMENSIONS ARE FOR REFERENCE ONLY
2. CUSTOMER DRAWING ONLY, NOT USED FOR CINCH MANUFACTURE
3. PART MARK CONNECTOR WITH CINCH
4. ALL OTHER DETAILS AND DIMENSIONS IAW MIL-DTL-83513 OR CINCH DURA-CON CATALOGUE

CONNECTOR SIZE	L	M	N	R	W
9P	.775	.334		.565	.298
15P	.925	.484		.715	.298
21P	1.075	.634		.865	.298
25P	1.175	.734		.965	.298
31P	1.325	.884		1.115	.298
37P	1.475	1.034		1.265	.298
51P	1.425	.984		1.215	.341
100P	2.160	1.384		1.800	.384
9S	.775		.334	.565	.298
15S	.925		.484	.715	.298
21S	1.075		.634	.865	.298
25S	1.175		.734	.965	.298
31S	1.325		.884	1.115	.298
37S	1.475		1.034	1.265	.298
51S	1.425		.984	1.215	.341
100P	2.160		1.384	1.800	.384

SALES-CODE NOMENCLATURE

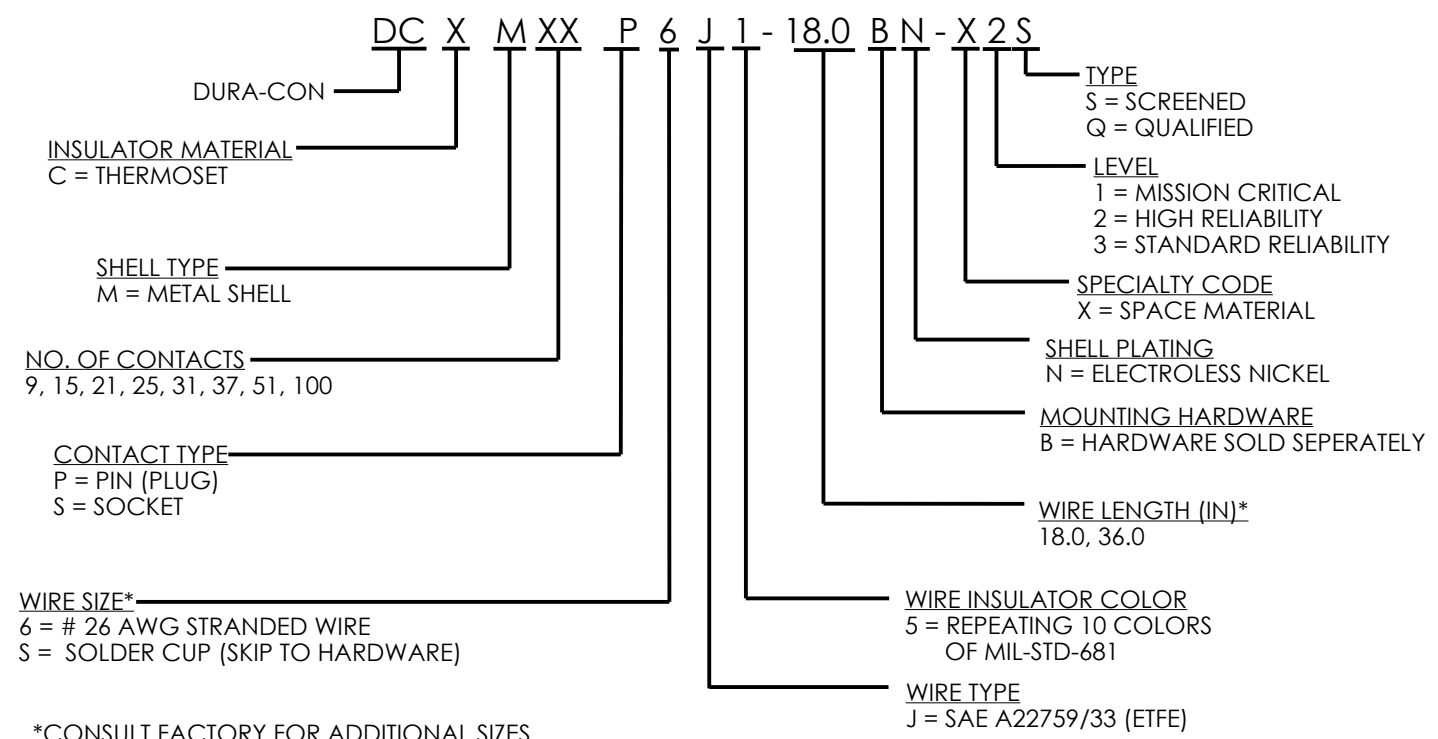

*CONSULT FACTORY FOR ADDITIONAL SIZES

UNITS ENGLISH INCHES	DESIGN ENGINEER J. WARRAICH	PRO/E DATE 12/15/23	MODELED BY:
DO NOT SCALE DRAWING			1700 FINLEY RD LOMBARD, IL 60148
UNLESS OTHERWISE SPECIFIED: ALL DIMENSIONS ARE IN INCHES	TITLE SPACE SCREENED MICRO-D METAL SHELL ASSEMBLIES		
FILLET/RADII .02 MAX.	TOLERANCES .X ± .1 .XX ± .01 .XXX ± .005 ANGULAR ± .5°		CONTROL SPEC NUMBER
CONFIDENTIAL THIS DOCUMENT IS THE PROPERTY OF CINCH. NEITHER THIS DOCUMENT NOR ANY OF THE INFORMATION CONTAINED IN IT MAY BE DUPLICATED OR DISCLOSED WITHOUT PRIOR WRITTEN CONSENT OF CINCH. ©COPYRIGHT CINCH	APPROVALS ON FILE		PROJECT NUMBER
	CAD FILE NUMBER SPACE_SCREENED_MICRO-D	DRAWING NUMBER SPACE SCREENED MICRO-D	SCALE 3:1
	CAGE IDENT NO. 71785	SIZE B	SHEET 1 OF 1