

# IP68 Rated Waterproof Interconnects

Introducing the Johnson waterproof interconnect family consisting of a rugged design for harsh environments. All products meet industry-leading IP68 standards. The parts are designed with internal gaskets along with an outer gasket. They are waterproof in an unmated condition and designed for underwater applications including mil-aero, transportation, oil & gas, marine and Industrial IoT. The part range consists of RF jack and plug connectors and adapters in the SMA, TNC, MCX and MMCX families. Available in stainless steel and brass.



## Features

- The SMA family operates up to 18 GHz.
- The TNC family are larger and more rugged.
- Adapters include hermetically sealed connectors to 1 x 10<sup>-8</sup> cc/sec, making them ideal for high pressure, vacuum applications and the prevention of liquid or gas leakage.
- Ingress Protection ratings are used to specify the environmental protection of enclosures and casings around electronic products.
- IP68 devices backed by an international standard rating of IP68 are deemed fit enough to withstand dust, dirt and sand, and are resistant to submersion up to a maximum depth of 1.5m underwater for up to thirty minutes.

## Applications

- Satellite communication equipment and base stations
- Remote monitoring communication
- Cable broadcast equipment
- GPS antennas

## IP68

1 <sup>st</sup> Digit	Definition
0	No protection against contact and ingress of objects
1	Protect against any large surface of the body, such as the back of hand. Protect against solid objects greater than 50mm in size.
2	Protect against access to hazardous parts by a finger or similar object. Protected against solid objects greater than 12.5mm in size.
3	Protected against access to hazardous parts with a tool or thick wire. Protected against solid objects greater than 2.5mm in size.
4	Protected against access to hazardous parts with a wire screw, etc. Protected against solid objects greater than 1mm in size.
5	Protected against access to hazardous parts. Dust protected.
6	Protected against access to hazardous parts. Dust-tight.

2 <sup>nd</sup> Digit	Definition
0	No protection
1	Protected against water drops.
2	Protected against water drops at a 15° angle.
3	Protected against water spray at 60° angle.
4	Protected against water splashing from any angle.
5	Protected against water jets from any angle.
6	Protected against powerful water jets and heavy seas.
7	Protected against the effects of temporary submerison in water. Test requires 30 minutes at 1 meter depth.
8	Protected against the effects of temporary submerison. Customer specification applies and specific testing may be required.
9K	Protects against high pressures associated with steam cleaning.

# IP68 Rated Waterproof Interconnects



## Connectors

### TNC Straight Clamp Plug, RG316

Part Number	Material	Impedance	Maximum Frequency	VSWR
137-0203-001	Stainless Steel Passivated	50 Ohms	DC - 26.5 GHz	1.20 Max

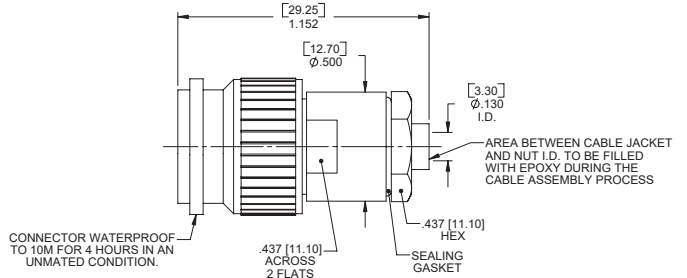
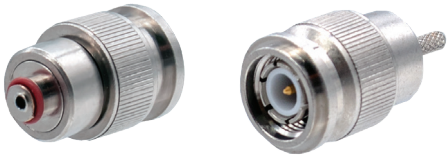

### TNC Straight Crimp Plug, RG316

Part Number	Material	Impedance	Maximum Frequency	VSWR
137-0403-011	Stainless Steel Passivated	50 Ohms	DC - 26.5 GHz	1.20 Max

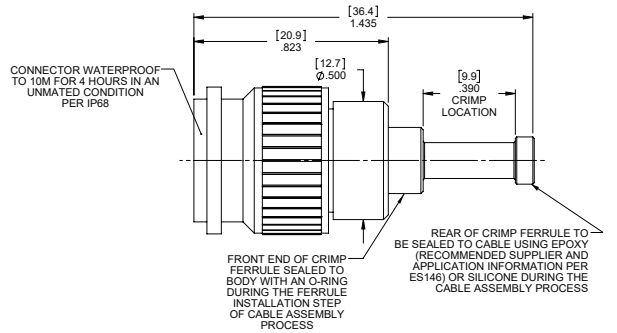
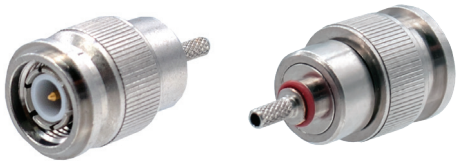

### TNC R/A Crimp Plug, RG316, Low Profile

Part Number	Material	Impedance	Maximum Frequency	VSWR
137-0403-101	Stainless Steel Passivated	50 Ohms	DC - 26.5 GHz	1.20 Max

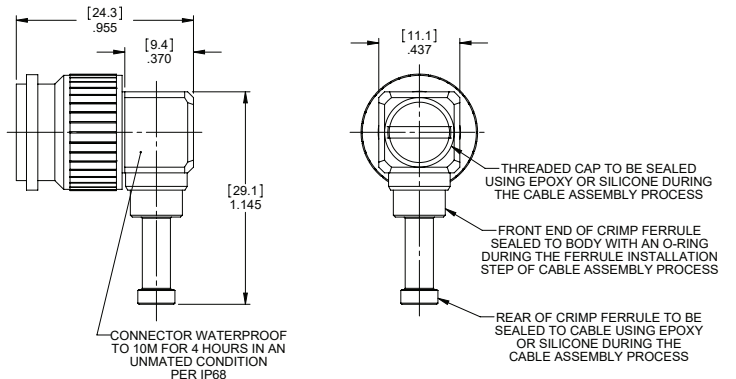

# IP68 Rated Waterproof Interconnects



## TNC Bulkhead Mount Jack, 0.085" Cable, Front Mount

Part Number	Material	Impedance	Maximum Frequency	VSWR
137-0599-411	Stainless Steel Passivated	50 Ohms	DC - 26.5 GHz	1.20 Max

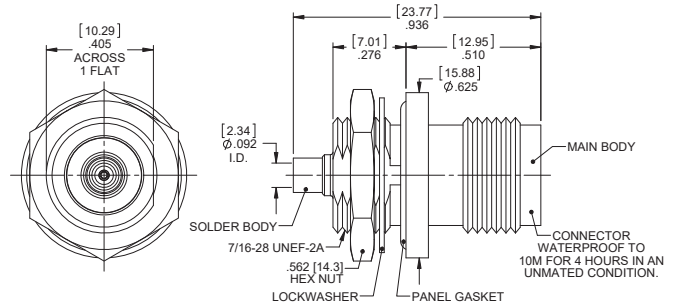
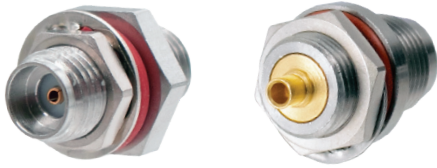

## SMA Crimp Bulkhead Jack, RG174/RG316/LMR100

Part Number	Material	Impedance	Maximum Frequency
142-0303-801	Stainless Steel Passivated	50 Ohms	DC - 18 GHz

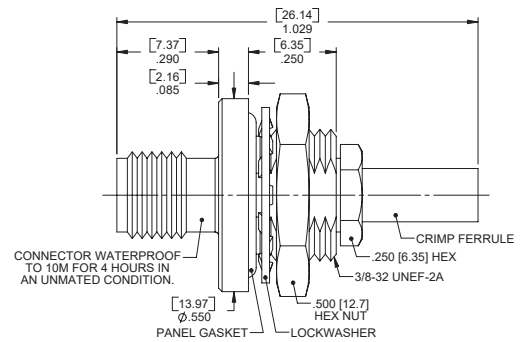
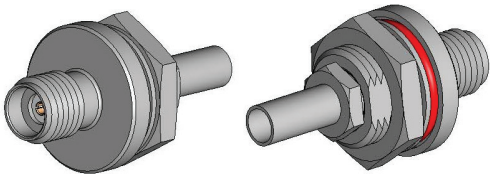

## SMA Crimp Plug, RG174/RG316/LMR100

Part Number	Material	Impedance	Maximum Frequency
142-0403-051	Stainless Steel Passivated	50 Ohms	DC - 18 GHz

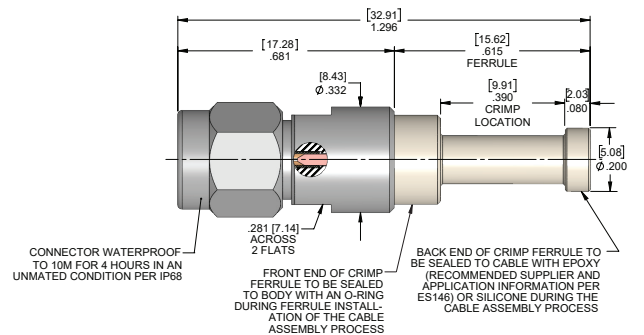

# IP68 Rated Waterproof Interconnects



## Adapters

### SMA Jack to MCX Bulkhead Adapter with Hex Nut

Part Number	Material	Impedance	Maximum Frequency	Dielectric Withstanding Voltage
134-1001-401	Brass, Nickel Plated	50 Ohms	DC - 6 GHz	1,000 VRMS

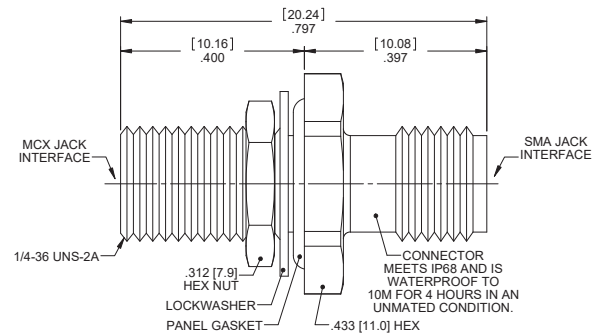

### SMA Jack to MCX Bulkhead Adapter without Hex Nut

Part Number	Material	Impedance	Maximum Frequency	Dielectric Withstanding Voltage
134-1001-411	Brass, Nickel Plated	50 Ohms	DC - 6 GHz	1,000 VRMS

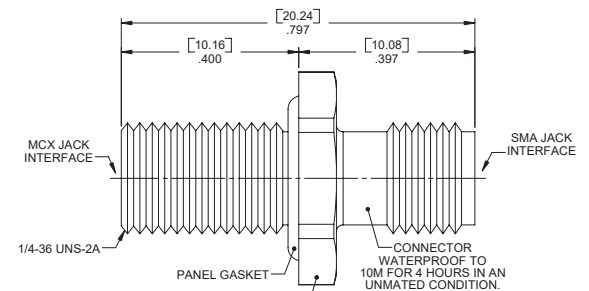

### SMA Jack to MMCX Jack Bulkhead Adapter

Part Number	Material	Impedance	Maximum Frequency	Dielectric Withstanding Voltage
134-1001-421	Brass, Nickel Plated	50 Ohms	DC - 6 GHz	1,000 VRMS

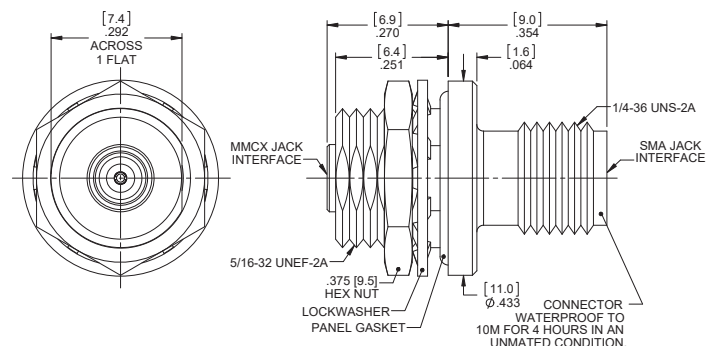

# IP68 Rated Waterproof Interconnects



## TNC Jack to SMA Jack Bulkhead Adapter

Part Number	Material	Impedance	Maximum Frequency	Dielectric Withstanding Voltage
134-1001-461	Stainless Steel Passivated	50 Ohms	DC - 6 GHz	1,000 VRMS

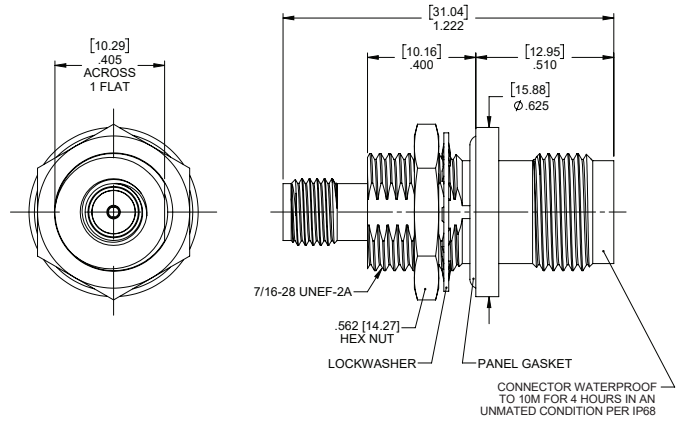
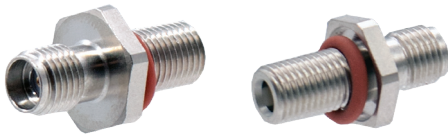

## TNC Jack to MCX Bulkhead Adapter

Part Number	Material	Impedance	Maximum Frequency	Dielectric Withstanding Voltage
134-1001-441	Brass, Nickel Plated	50 Ohms	DC - 6 GHz	1,000 VRMS

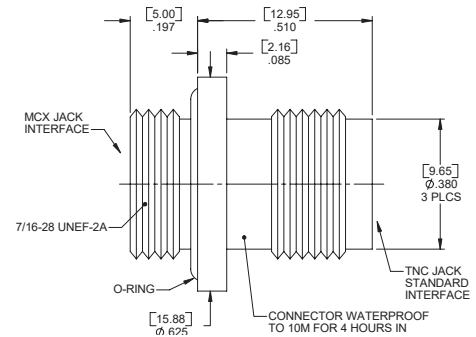

## TNC Jack to MCX Bulkhead Adapter with Hex Nut

Part Number	Material	Impedance	Maximum Frequency	Dielectric Withstanding Voltage
134-1001-451	Brass, Nickel Plated	50 Ohms	DC - 6 GHz	1,000 VRMS

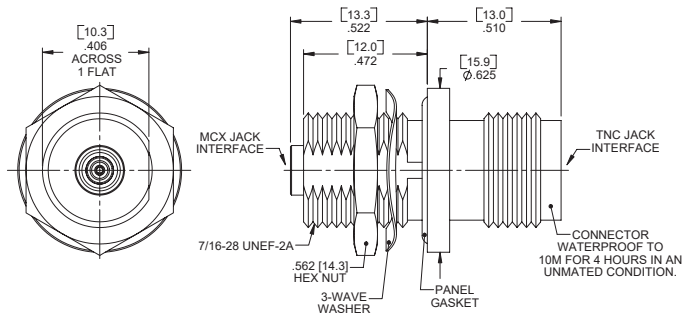

# IP68 Rated Waterproof Interconnects



## SMA Jack to SMA Jack Bulkhead Adapter

Part Number	Material	Impedance	Maximum Frequency	Dielectric Withstanding Voltage
142-0901-431	Brass, Nickel Plated	50 Ohms	DC - 18 GHz	1,000 VRMS

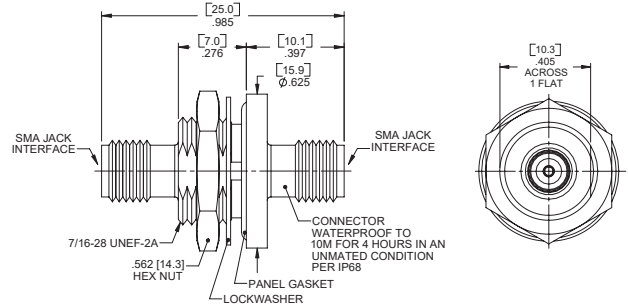

## Contacts

### SMA Bulkhead Jack, Solder Pot Contact

Part Number	Material	Impedance	Maximum Frequency	Dielectric Withstanding Voltage
142-1701-401	Brass, Nickel Plated	50 Ohms	DC - 6 GHz	1,000 VRMS

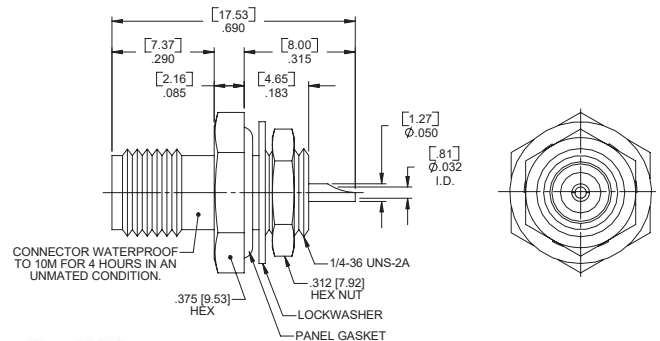

### SMA Bulkhead Jack, Tab Contact

Part Number	Material	Impedance	Maximum Frequency	Dielectric Withstanding Voltage
142-1701-411	Brass, Nickel Plated	50 Ohms	DC - 6 GHz	1,000 VRMS

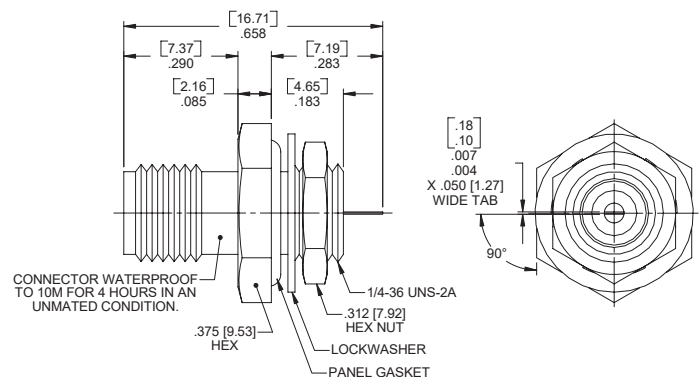

# IP68 Rated Waterproof Interconnects



## SMA Bulkhead Jack, Post Contact

Part Number	Material	Impedance	Maximum Frequency	VSWR
142-1701-421	Stainless Steel Passivated	50 Ohms	DC - 26.5 GHz	1.20 Max

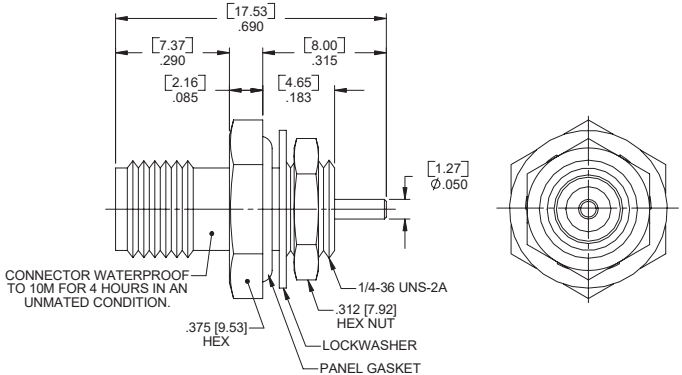

**Asia Pacific**  
 +86 21 5442 7668  
 ccs.asia.sales@as.cinch.com

**Europe, Middle East & Africa**  
 +44 (0) 1245 342060  
 cinchconnectivity@eu.cinch.com

**North America**  
 +1 507 833 8822  
 ccsorders@us.cinch.com

[belfuse.com/cinch](http://belfuse.com/cinch)