

PART NUMBER	ITEM 1 BODY	ITEM 2 INSULATOR	ITEM 3 CONTACT	ITEM 4 END CAP
125-0693-101	BERYLLIUM COPPER GOLD PL .00005 MIN OVER NICKEL PL .00005 MIN OVER COPPER PL .00005 MIN	TEFLON	BERYLLIUM COPPER GOLD PL .00005 MIN OVER NICKEL PL .00005 MIN OVER COPPER PL .00005 MIN	BRASS GOLD PL .00001 MIN OVER NICKEL PL .00005 MIN OVER COPPER PL .00005 MIN

REV	ECO	DATE
1	INITIAL RELEASE	06/04/2019
2	EC-1912001	12/09/2019

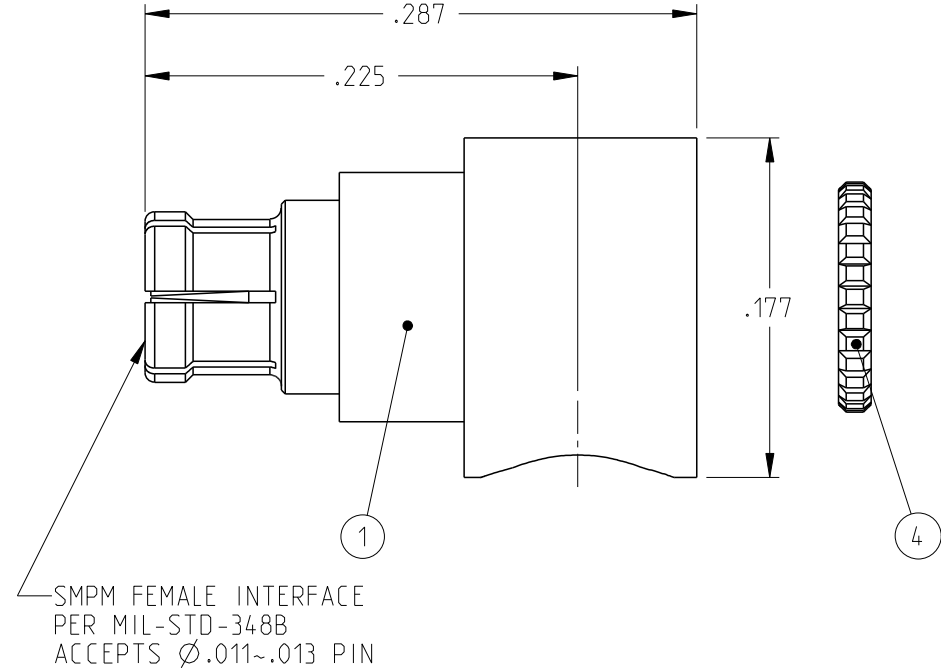
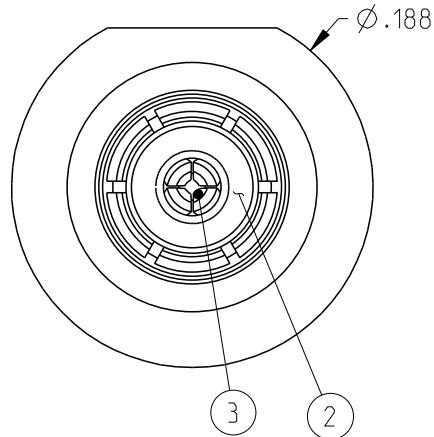

SMPM FEMALE INTERFACE
PER MIL-STD-348B
ACCEPTS Ø.011~.013 PIN

SPECIFICATION:

1. ELECTRICAL SPECIFICATIONS:
 - 1.1 FREQUENCY RANGE: 0-40 GHz
 - 1.2 IMPEDANCE: 50 OHMS
 - 1.3 VSWR: 1.30 MAX TO 26.5GHz, 1.6 MAX TO 30GHz
 - 1.4 INSERTION LOSS: 0.12 √F dB MAX (F IN GHz)
 - 1.5 WORKING VOLTAGE (MAX): 335 VRMS AT SEA LEVEL
 - 1.6 DIELECTRIC WITHSTANDING VOLTAGE (MIN): 325 VRMS AT SEA LEVEL
 - 1.7 INSULATION RESISTANCE (MIN): 5000 MEGOHMS
 - 1.8 CONTACT RESISTANCE:
 - 1.8.1 CENTER CONTACT: INITIAL 6 MILLIOHMS MAX, AFTER ENVIRONMENTAL NOT APPLICABLE
 - 1.8.2 OUTER CONDUCTOR: INITIAL 2 MILLIOHMS MAX, AFTER ENVIRONMENTAL NOT APPLICABLE
 - 1.9 RF LEAKAGE: -80dB TYPICAL AT 3 GHz
2. MECHANICAL SPECIFICATIONS:
 - 2.1 ENGAGEMENT FORCE: FULL DETENT(FD) 4.5LBS TYPICAL; SMOOTH BORE(SB) 2.5 LBS TYPICAL
 - 2.2 DISENGAGEMENT FORCE: FD 6.5LBS TYPICAL; SB 1.5LBS TYPICAL
 - 2.3 CONTACT RETENTION: 1.5 LBS MIN AXIAL FORCE
 - 2.4 DURABILITY(MIN): FD 100 CYCLES; SB 500 CYCLES
3. ENVIRONMENTAL:
 - 3.1 THERMAL SHOCK: MIL-STD-202, METHOD 107, CONDITION B
 - 3.2 OPERATING TEMPERATURE: -65°C TO 165°C
 - 3.3 CORROSION: MIL-STD-202, METHOD 101
 - 3.4 MECHANICAL SHOCK: MIL-STD-202, METHOD 213, CONDITION I
 - 3.5 VIBRATION: MIL-STD-202, METHOD 204
 - 3.6 MOISTURE RESISTANCE: MIL-STD-202, METHOD 106, EXCEPT STEP 7B

<p>This PROPRIETARY Document is property of Cinch Connectivity Solutions. It is confidential in nature, non-transferable, and issued with the clear understanding that it is not traced or copied without permission and is returnable upon demand.</p> <p>INTERPRET DRAWING IN ACCORDANCE WITH ASME Y14.5-2009.</p>	<p>3RD ANGLE PROJECTION</p>	<p>JOHNSON</p>	
	<p>RoHS2 <input checked="" type="checkbox"/></p> <p>2011/65/EU</p>	<p>Title: SMPM FEMALE RIGHT ANGLE CABLED .086 SEMI-RIGID</p>	
	<p>UNLESS OTHERWISE SPECIFIED UNITS: INCH</p> <p>.XX ±.02 .XXX ±.010 ANGLES ±2°</p>	<p>Model No.</p> <p>125-0693-101</p>	<p>Size A</p>
		<p>DO NOT SCALE DRAWING</p>	<p>Sheet 1 OF 1</p>